

Plug-in Hybrid Electric Vehicle Conversion Kit

User Manual

You are strongly recommended to have a specialist to undertake the task!

HV (High Voltage) DC (Direct Current) Warning: Traction Battery Packs, Motors, Chargers, and other HV sources could cause serious injury or death if proper precautions are not taken while working on or around such High Voltage Direct Current sources.

Please note that anyone attempting to install this Conversion Kit and modify their vehicle is doing so at their own discretion and risk.

Warranty: In performing some of these modifications you may void your warranty with the vehicles manufacturer.

This is a patent pending application.

Product Overview

Plug-in Hybrid Electric Vehicle Conversion Kit (PHEV) is a rechargeable battery set supplementary to a Hybrid vehicle. It supplies electricity charged from AC wall socket for 20 to 40 mile mixed drive per charge, sufficient for normal daily commute. It is safe, reliable, cost saving and user and environmental friendly.

Product Specifications

16 / 32 cells for 2KWH / 4KWH, LiFePO4 batteries

Battery balancers—one for every 8 cells, monitoring and balancing battery voltage to avoid over or under charge individual cells, extending battery life by 3 times.

48V / 15A high power charger

3000W DC / DC Converter and Controller

Automatic circuit breaker to discontinue equipment operation at abnormal high current.

Easy installation, simple to use

Equipment work procedure:

110VAC household electricity→Enginer PHEV conversion kit→Hybrid vehicle OEM Stock battery→Hybrid electric motor.

Batteries	Type	Capacity	Average Gas Mileage mpg	EV/Mixed Range	Charge time hour
16 Cells	LiFePO4	40AH	85	10 (20)	3
32 Cells		80AH	85	20 (40)	5

- Use 110V AC source only.

Balancers: monitoring and balance battery cells. Each controls 8 cells.

Press “LiPo / LiFe: to select battery type, LiFe mode should be set for this equipment at all times. After setup, press Start / Stop to initiate balancer.

The balancer’s screen will show in order data of: Total voltage of the 8 cells, Voltage of individual cell, Standard deviation of voltage; A red dot flashes during balancing and turns off when voltage difference is less than 0.01V.

The balancer will alert if any cell voltage drops below 2.8V or is charged above 3.75V.

Attention

1. Please read instructions before installation.
2. Never wrongly connect wires.
3. New batteries should be re-charged to full before use.
4. Please check the batteries' voltage regularly at the first few times of usage.
5. Equipment must be recharged at 110VAC household electricity to full each time and fully balanced to extend battery life after charged.
6. Circuit breaker in the enclosure box shall be automatically switched off if the current is over the limit (100A). You will then need to resume the switch before use.
7. Please switch the equipment off if defect is found during driving.
8. Please do not disassemble components if the equipment is in normal working conditions.

Warranty

2 year limited parts warranty applies. If equipment defect occurs in normal use conditions, Engineer shall repair the equipment or change defect components in this conversion kit only.

Use this information at your own risk: There is no warranty expressed nor implied and we are not liable for any of your past, present, nor future actions. Even should you perform these modifications to the letter you could still damage any number of components in your vehicle causing it to no longer function. Even if it appears to function properly your actions may cause it to self destruct with collateral damage to surrounding properties other than your vehicle. By utilizing these ideas and instructions in an attempting to enhance national security, reduce gas consumption, vehicle "emissions", your carbon footprint, or smog, you do so at your own risk & peril.

Contacts**US Distributor:**

AutomationTech Inc.

www.automationtechinc.com

Toll Free: 877 886-8897

1562 Hamlet Drive, Troy, MI 48084, USA

Made By: Engineer EnvironmentTech Co. Ltd.

Web: www.engineer.us

Address: 1010 / 1701 Beijing Xi Road, Shanghai 200040, China

Preparing and Assembling the PHEV Conversion Kit

Please read carefully and comprehend this instruction before moving out the product.

Installation and Use

1. Prepare at least 2X2 meter flat ground near the end of your hybrid vehicle, and cover the floor with 1.5X1.5 meter soft and flat cloth or cardboard.
2. The equipment must be removed by two adults.
3. Knock open the wooden box and then open the cardboard box in side.
4. Take out accessory bags and check against the following list to see whether components are complete.
 - One 48cm lid supporting pole
 - One plastic holding bracket.
 - Two 3cm red and black jumper wires with ring terminal.
 - One red and one black parallel connection bars (Optional 4KWH batteries)
 - ECU signal wires (red, black and white)
 - One switch panel with on/off switch, red and green LED lights
 - 4 sets of equipment mounting brackets and screws
 - Two screws with handle
 - One double-sized spanner
 - A set of two fire extinguisher holders and mounting screws.
5. Place the above accessories in a place not impeding the installation. Take out the foam plastic cover from the cardboard box and pull out the stainless steel box by two people with both hands, carefully and steadily move out the entire equipment and place it gently on the floor. Do not incline or turn over the equipment, avoid scratching the product.
6. The equipment weighted 55—80 kg. Enginer strongly suggests you use professional lifting equipment, or operators should be strong enough. Slowly handle the equip-

ment to avoid injury or equipment damage.

7. Take the supporting pole from accessories and hold it with your right hand. Open the enclosure box cover and stick the pole in the hole at right hand side close to your body and prop up the cover on the other end. Take out a white small plastic bracket holder from accessories and push it hard to a small hole on right side to rest the pole after use.
8. After popping up the cover firmly, take out all insulating foams gently and check inside component against the following list:
 - Stainless steel box and cover (796.4×520.0×180.0mm)
 - Batteries: 2 sets of 8 cells (2KWH), or 4 sets of 8 cells (4KWH) depending on your order. Please make sure batteries match your order.
 - Two battery mounting frames to fix the two rows of batteries.
 - Balancers fixed on the rear battery frame: two for 2KWH kit or 4 for 4KWH kit, black, each linking 8 cells with wires.
 - One converter connected back left, connecting batteries with one red and one black power inlet wires with a pair of Anderson plug. It also contains one red and one black power outlet, and a 6 pin cable.
 - One charger connected on right back connecting black power inlet cable, with left hand side one red and one black cable with an Anderson plug.
 - One circuit breaker mounted on right lower conner

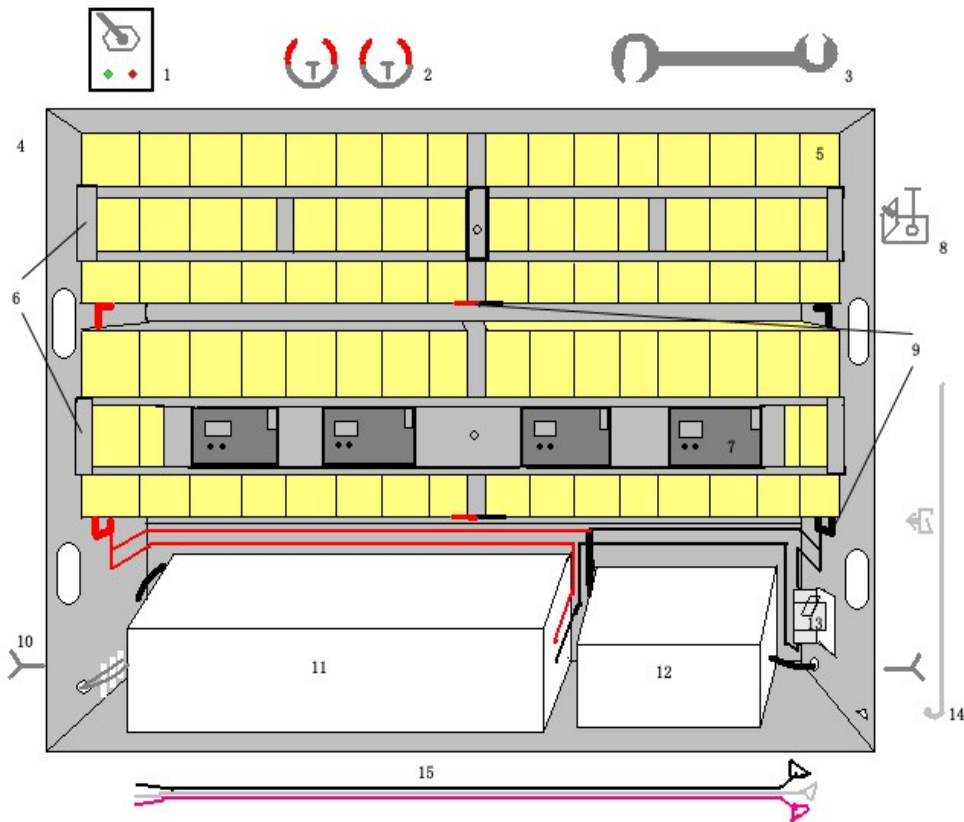

Figure 1: Component Layout

9. Wiring Check: ①Make sure circuit breaker is in the OFF position,, Anderson plugs from charger and converter are disconnected, balancers' interfaces are pulled off; ②charger and converter connections are connected firmly; ③Connection between black wires from converter and circuit breaker is connected firmly; ④Connection between circuit breaker and another black wire is connected firmly. ⑤positive and negative of each group of batteries are connected firmly (16 cells in series, two 16 cell packs in parallel shown in FIG1) , terminal plastic covers are in position.

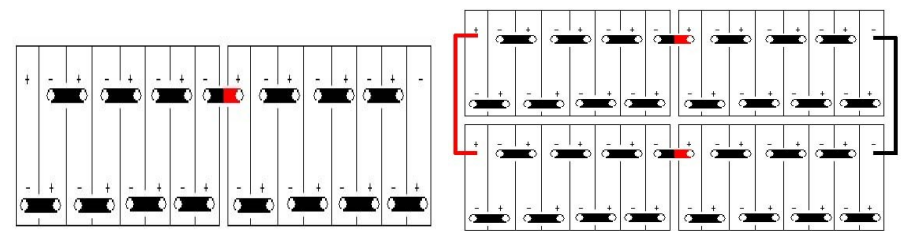

Figure 2: Connection of one row batteries (2KWH) Connection of two rows of batteries (4KWH)

- ⑥Connection between balancers and batteries are normal and firm:

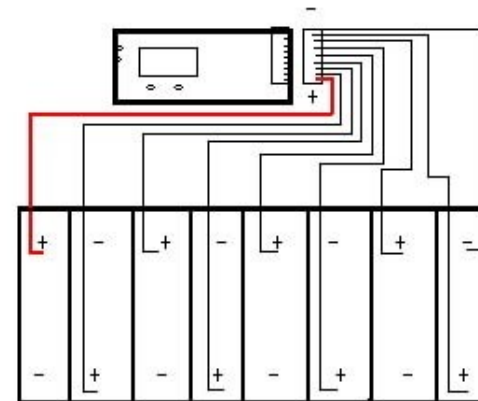

Figure 3: Balancer Connection

10. Wiring: ①Pull out the protection cap of the batter terminals (positive and negative) between two battery packs, use red/black short jumper cable to put them in series as shown in Figure 2. If it is 4KWH model, connect two strings of the 2KWH battery packs in parallel (positive to positive, negative to negative terminals) ②Connect the DC/DC converter(11) to the end terminals of the battery pack, red to positive and black for negative. ③Connect the white connectors to the balancers. ④Connect the gray Anderson connector to the charger.
11. Remove the lid supporting bar, close the cover and tighten two screws on both side of the cover.
12. The conversion kit assemble is completed and ready to be installed into the vehicle.

13. Bumper outlet for charger connection.



11. PHEV switch panel operation:

ON: Turn on PHEV DC/DC Converter (LED Green---On; Red—Battery Low)

OFF: Turn off PHEV DC/DC Converter (LED Green-- Off)

Connecting Engineer PHEV Conversion Kit to a Toyota Prius

Installation Time: 2-3 hours by professionals, 6 hours or longer by first timers.

Before installation, please be advised to login to Toyota Technical Website

techinfo.toyota.com for Reference Instructions. (\$15 for two day usage as of June 2009)

Installation Procedure

1. Stop your Prius engine completely by removing t car key
2. Remove truck interior cover on the back of the back seat to gain access to OEM stock battery orange service plug and unplug it.

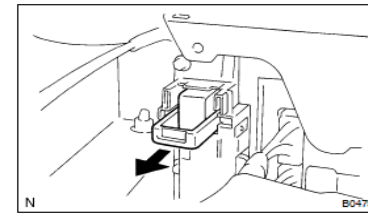

3. Remove auxiliary battery negative terminal.
4. Mount your Engineer PHEV Conversion Kit to the truck.
 - A. Mark four mounting holes according to size and dimension of the Kit's mounting brackets.
 - B. Drill and tap #10 screw on the truck floor plate
 - C. Tighten four mounting screws with washier and spring ring.

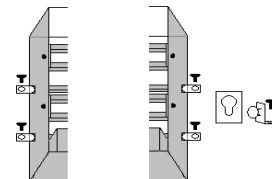

5. Remove back seat and gain access to the OEM stock battery output terminals

Prius 2000-2003 Model (Reference: HV-4 HYBRID VEHICLE CONTROL – HV BATTERY)

- A. Pull up the seat cushion pad front edge toward back.
- B. Remove back cushion screws and pull it up.
- C. Remove battery carrier catch bracket to access to power cable terminal. The upper terminal is positive, the lower is negative.

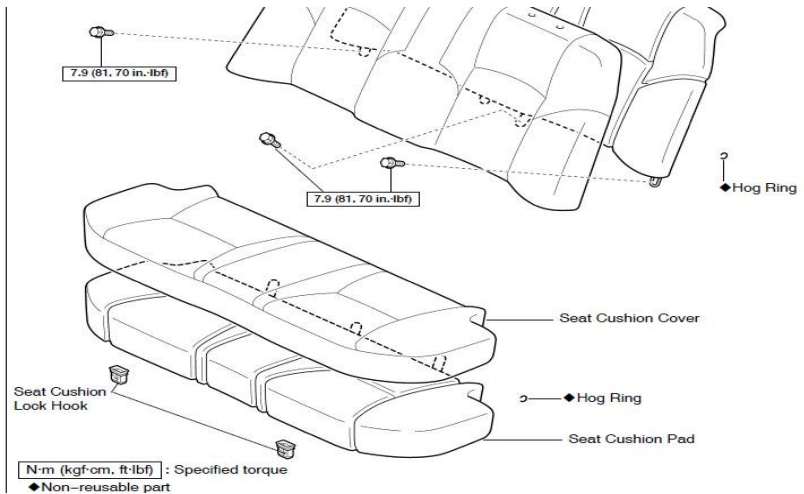

2000-2003 Model Shown

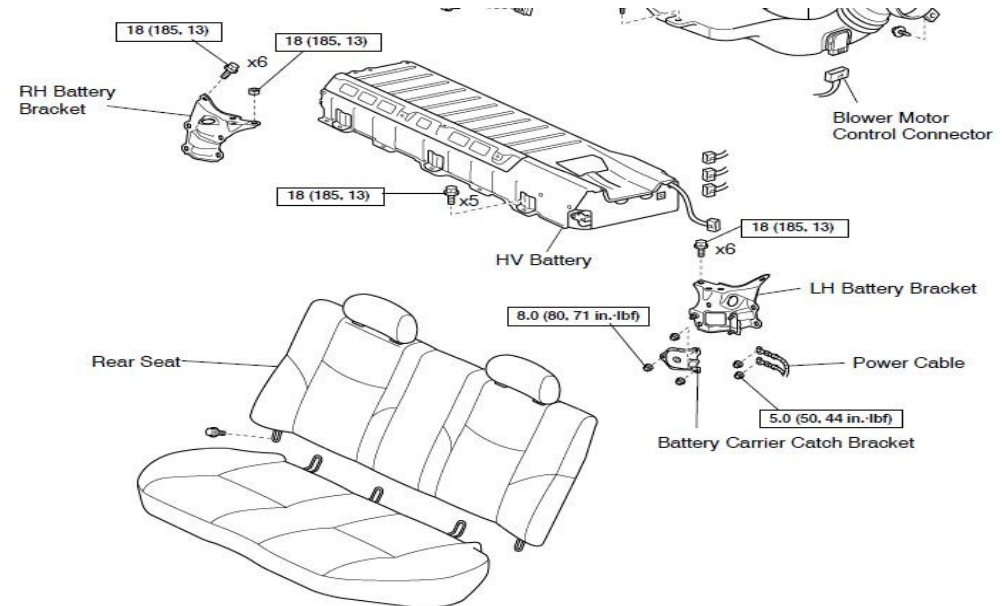

2000-2003 Model Shown

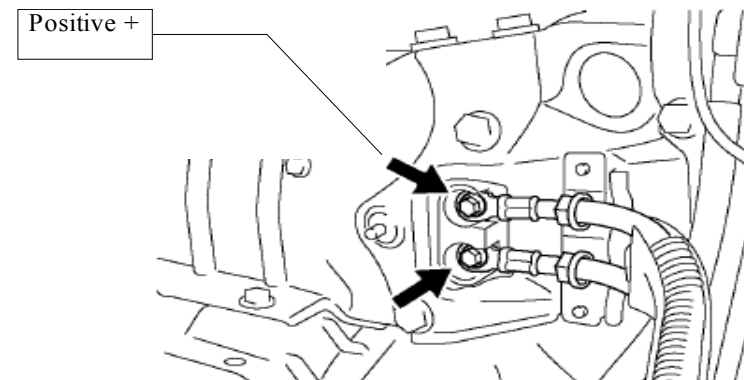

2004-2009 Model. (Reference: 21-54 HYBRID CONTROL SYSTEM – HV BATTERY)

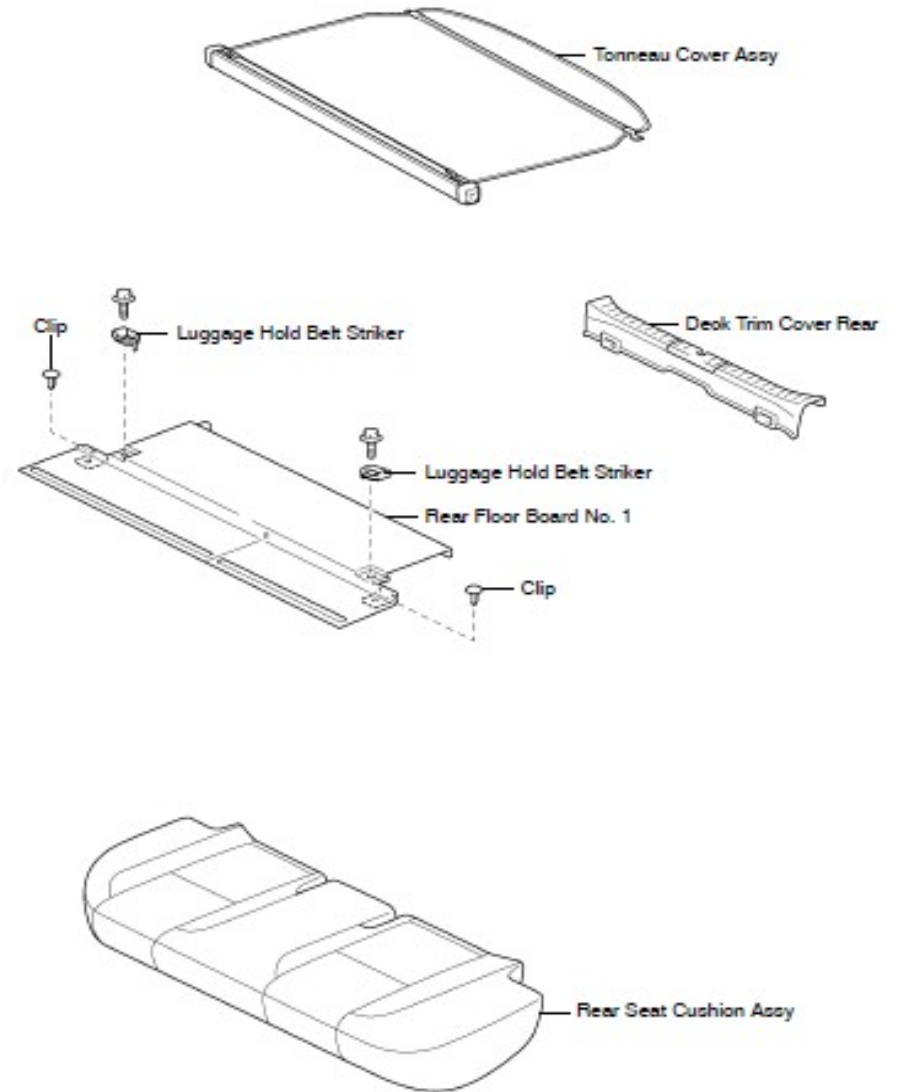
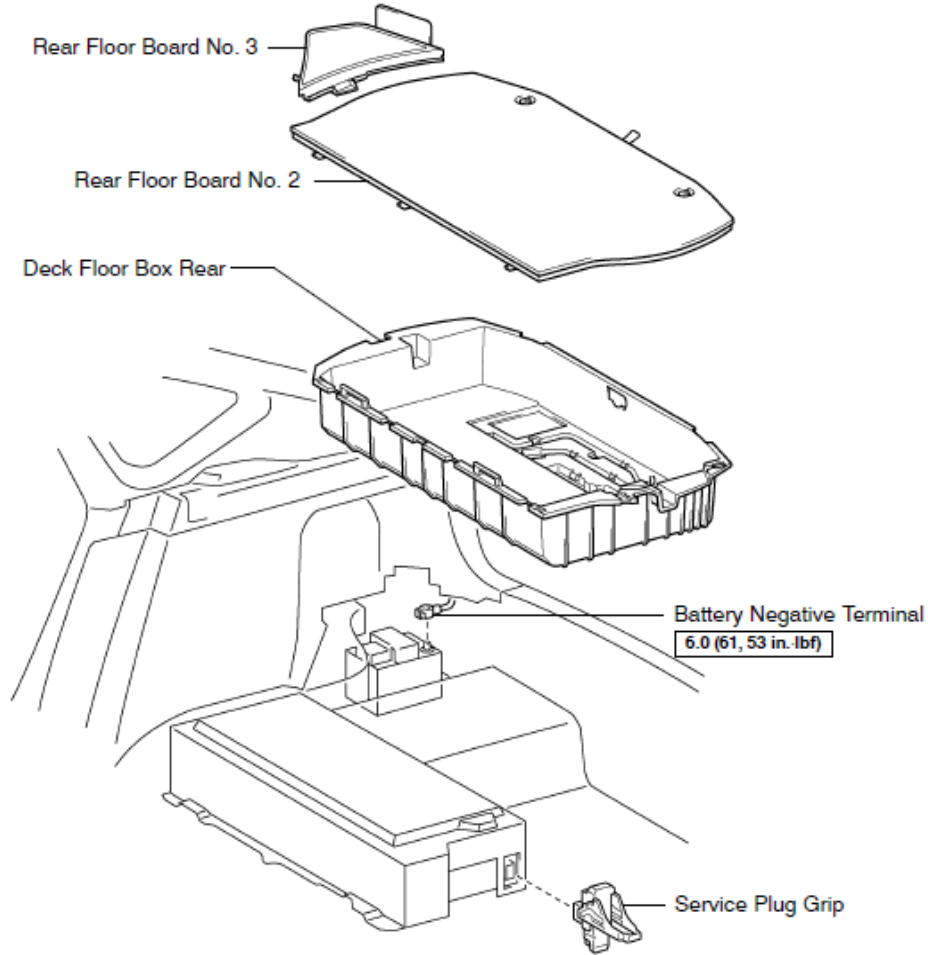

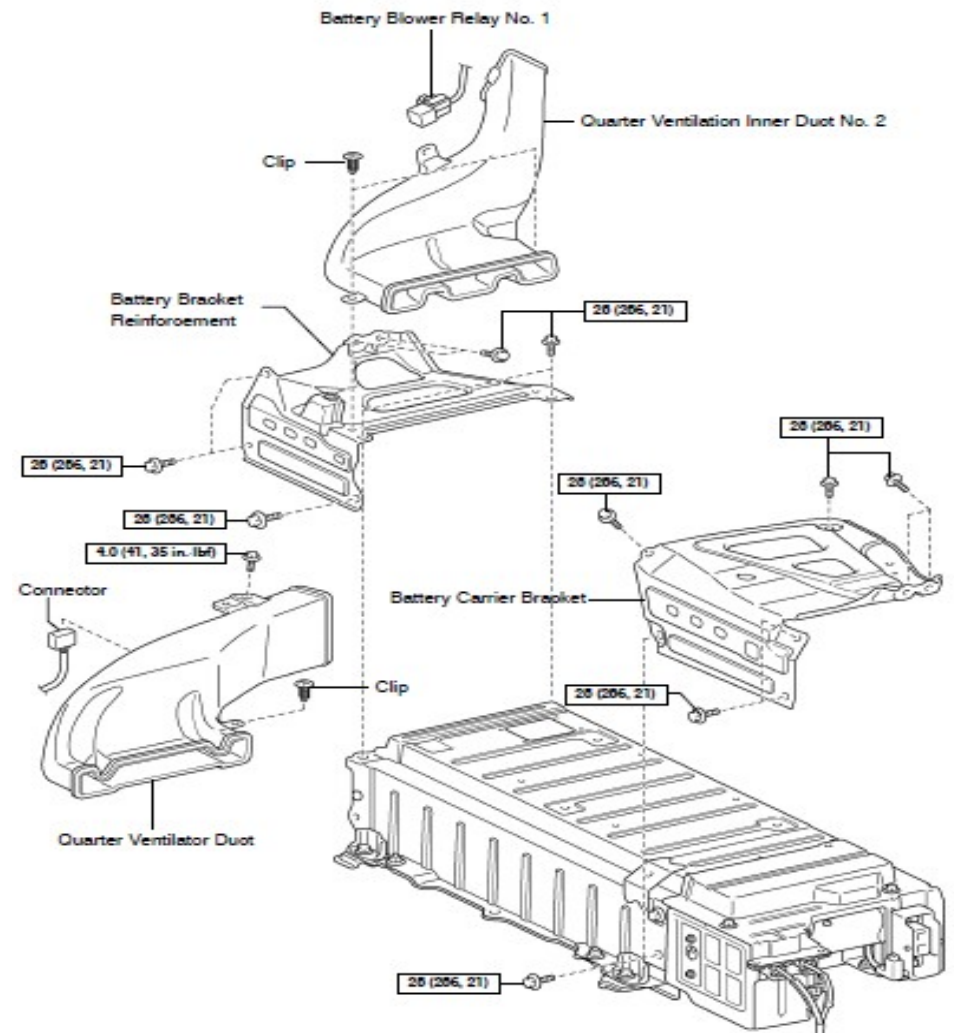
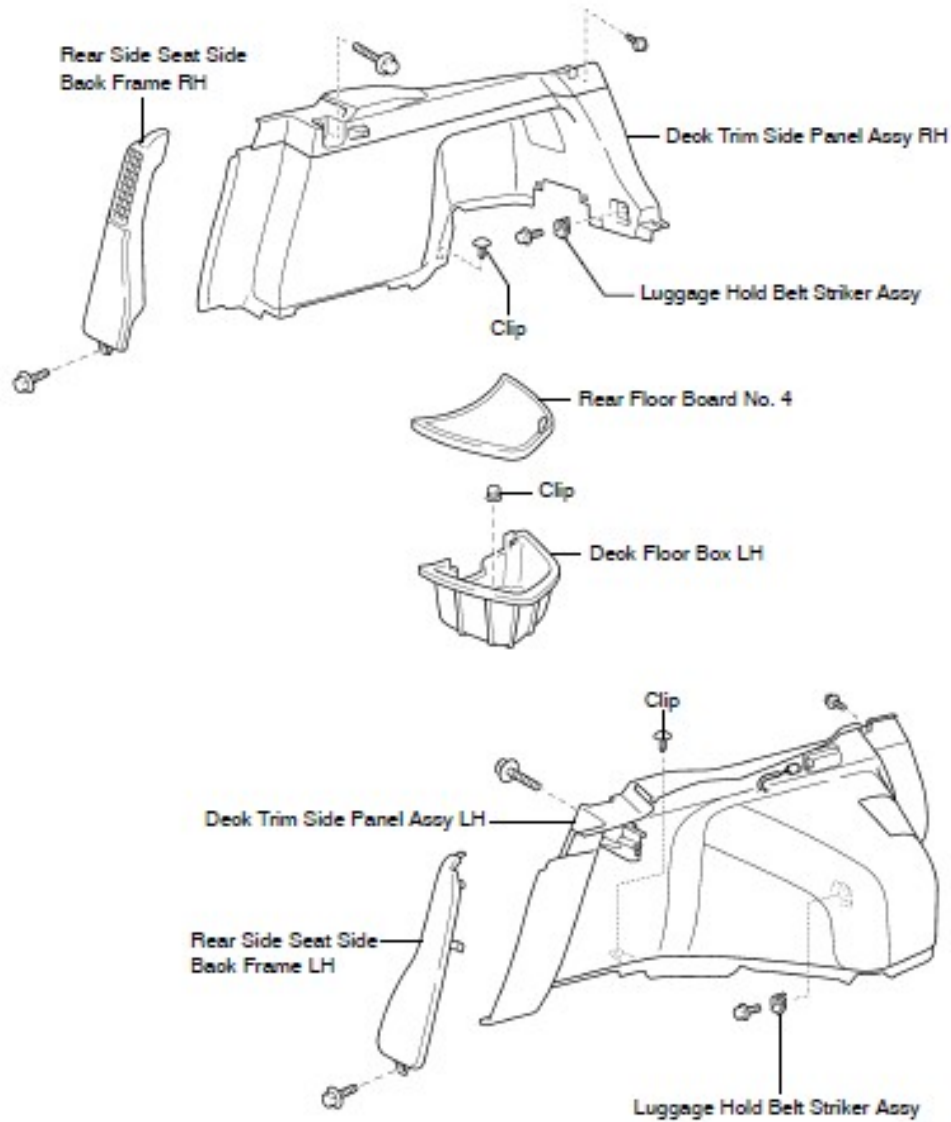

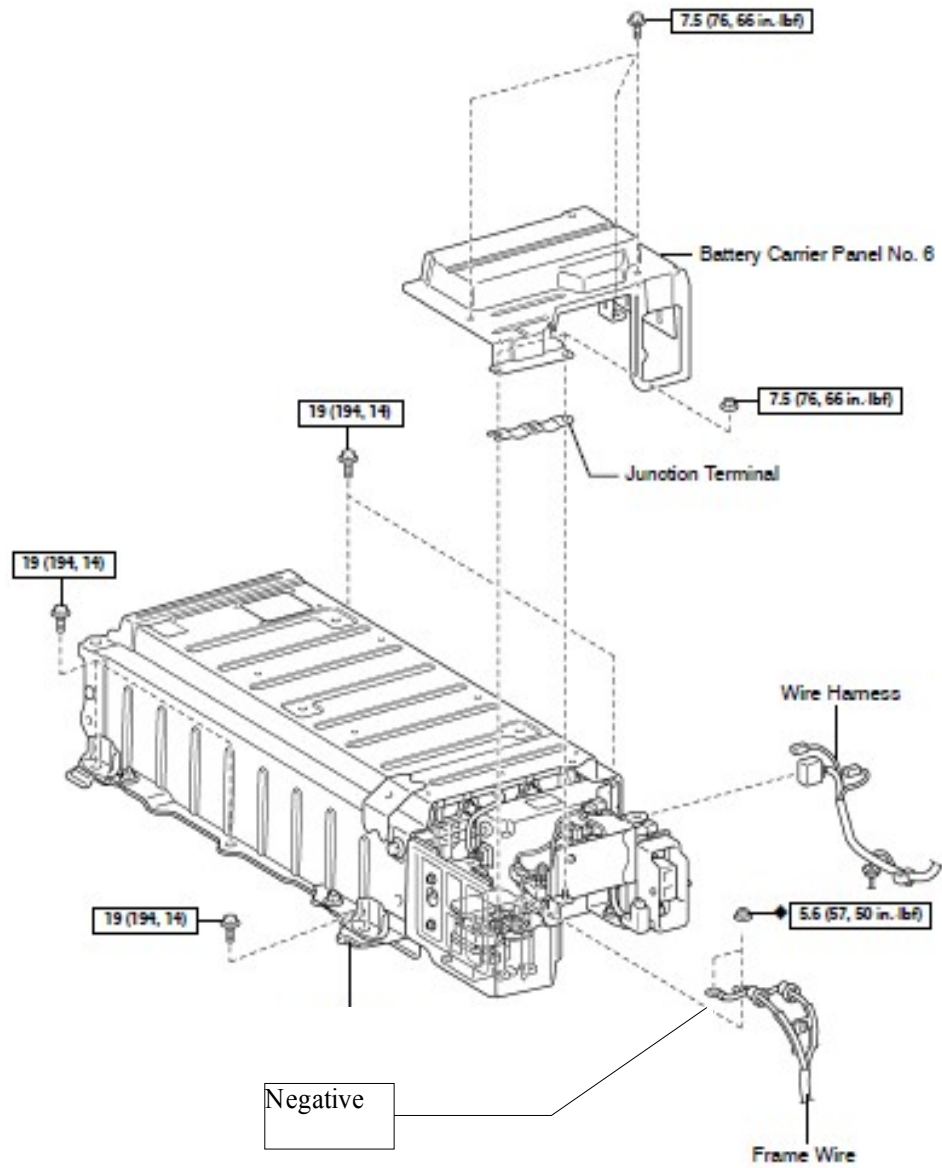

2010 Prius Model (Reference:RM000002XNW00LX)

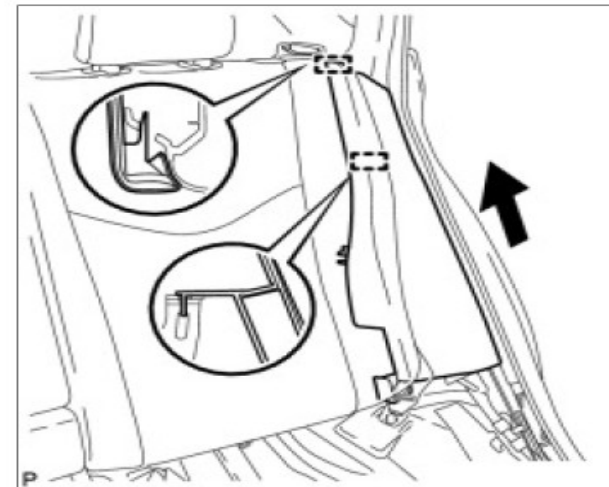
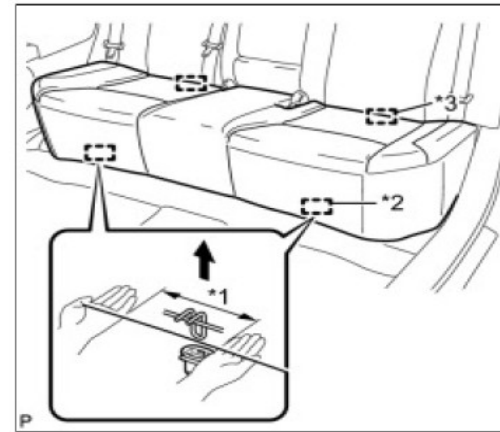

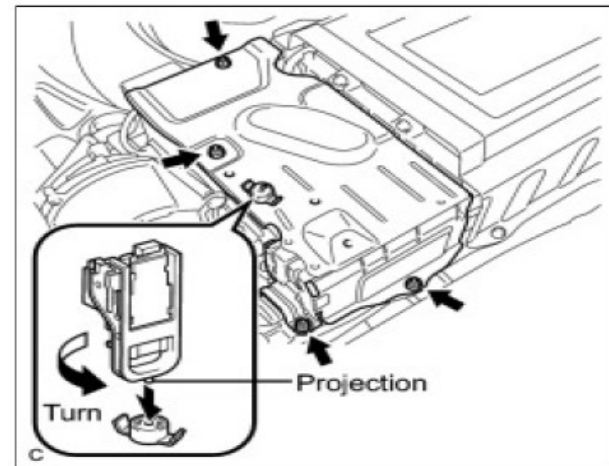
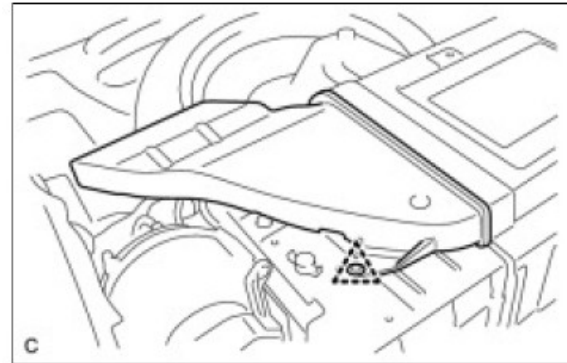
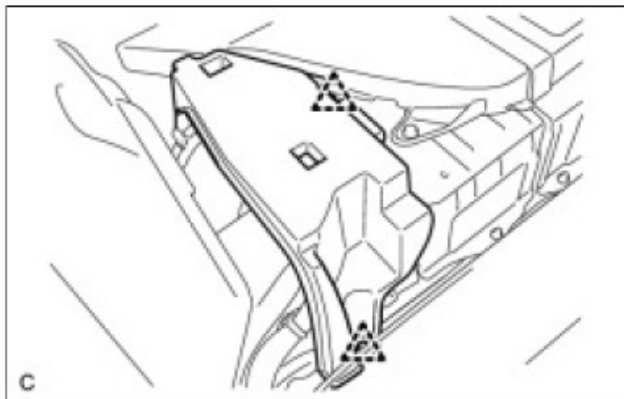
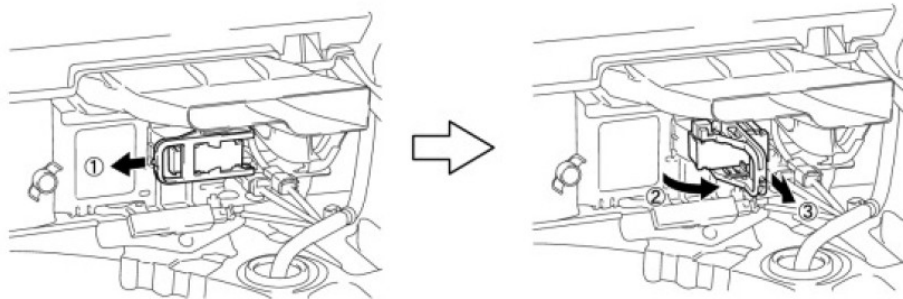
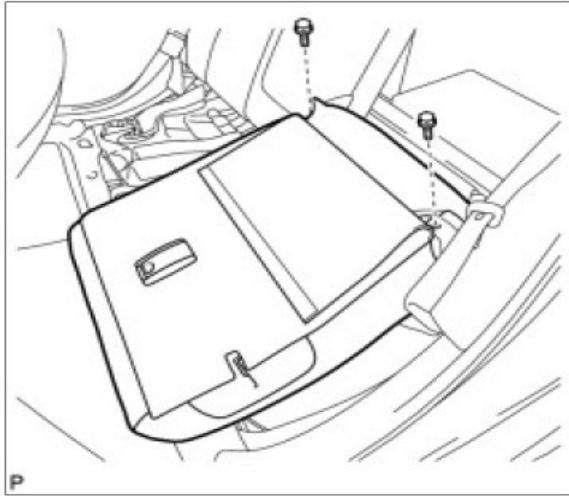

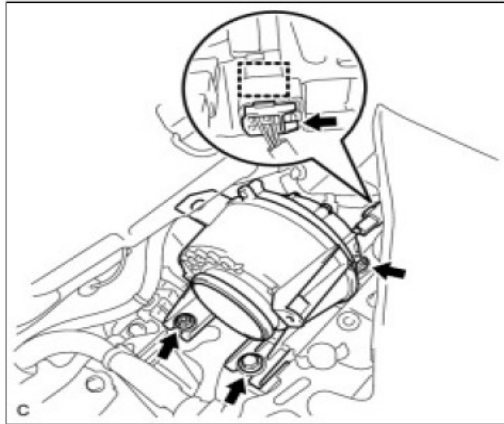

5. Connect the conversion kit's power cable to positive and negative terminals of the stock battery output power cable.

6. Install on/off switch panel.

A. Take off the blank panel on the left hand side of your meter board

B. Drill three holes for the switch and the 2 LED lights to fit in (6mm for the switch, 3mm for each LED light)



C. Loosen the switch bolt, place it on through the panel hole and tighten it on the panel.

7. Hook up ECU Ignition Ready signal to on/off switch panel

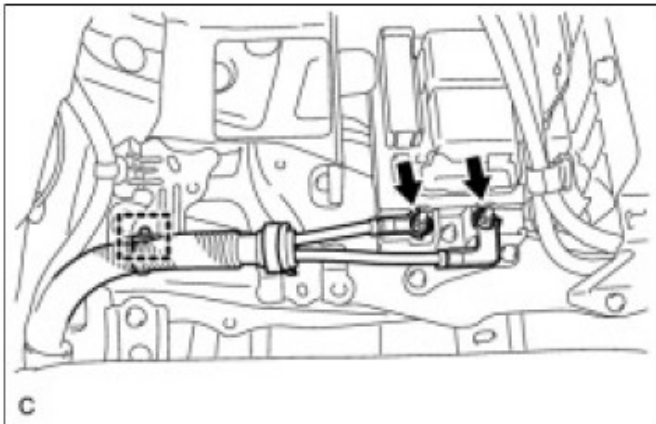

2000-2003 Model (Reference: DI-20 Terminals of ECM)

CON2 (H12-2) –Grey: Ignition Ready (Connect to the Red wire of PHEV switch panel)

GND1 (H14-31) - White/Black: Ground (Connect to the White/Black wire of PHEV switch panel)

White wire is not connected for 2000-2003 Model

HV ECU Terminals

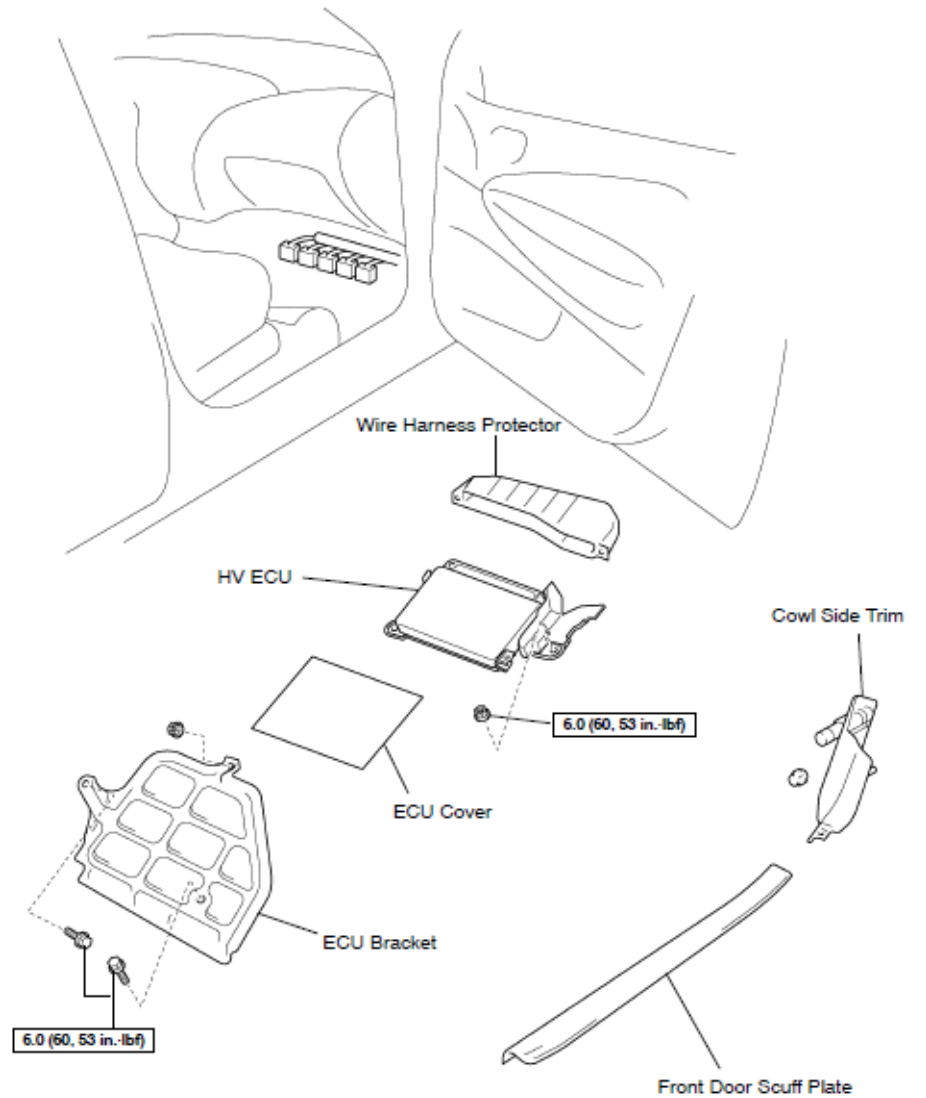
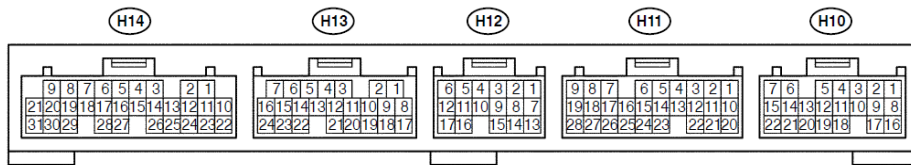

2004-2009 Model (Reference: 05-408 DIAGNOSTICS – HYBRID CONTROL SYSTEM)

CON2 (H16-2) – Green: Ignition Ready (Connect to the Red wire of PHEV switch panel)

GND1 (H14-1) – White-Black: Ground (Connect to the White/Black wire of PHEV switch panel)

EV (H14-27) – Blank Pin: EV Mode (Connect to the White wire of PHEV switch panel)

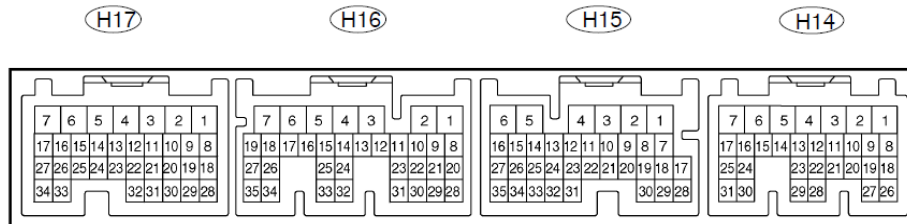

Add EV switch wire (Reference: <http://www.calcars.org/prius-evbutton-install.pdf>)

EV Button Modification for '04 Americas Prius

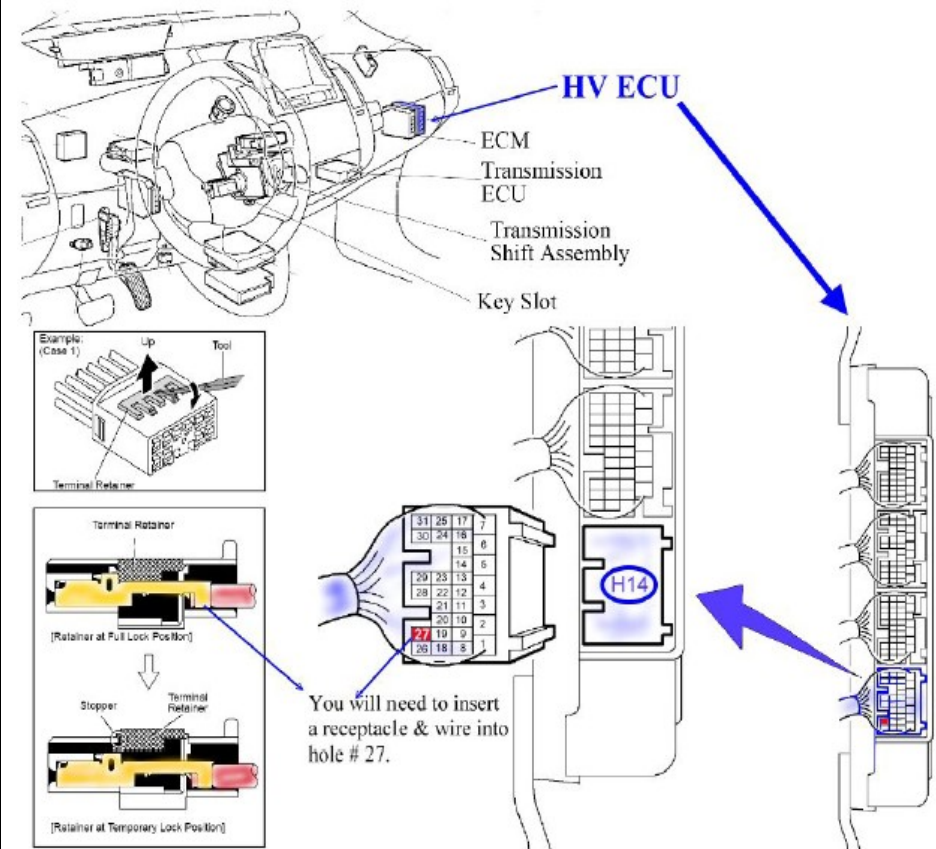

Please note that anyone attempting to do this modification is doing so at their own discretion and risk.

2010 Prius Model (Reference: X387000000801LD)

Power Management Control ECU

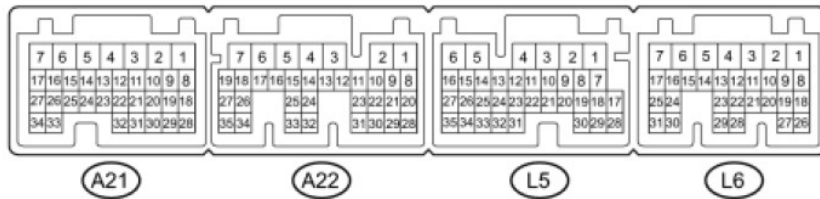

- SMRG (L5-2) – Yellow: Ignition Ready (Connect to the Red wire of PHEV switch panel)
- E01 (L5-5) – White-Red: Ground (Connect to the White/Black wire of PHEV switch panel)
- White wire is not connected for 2010+ Prius

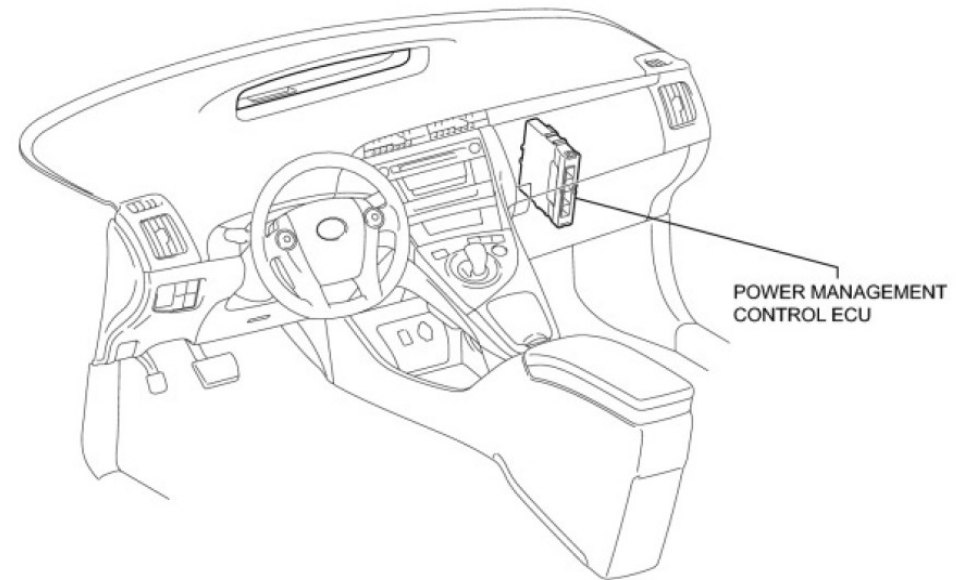

8. Hookup 6-Pin on/off switch panel cable to your Enginer battery box.

9. Drill a hole and mount Bumper AC Outlet

10. Re-Install back seat and trunk panels.

Your Enginer PHEV Conversion Kit installation is now complete. Please test the equipment in the following steps:

1. Charging batteries
2. Wait overnight for the cell to be balanced
3. Turn on circuit breaker
4. Turn off PHEV switch
5. Turn vehicle ignition key
6. Turn on PHEV switch. Power LED should turn green and Battery Low LED should be off.

Once all the above steps are completed and no defect occurs, you are safe to drive your Enginer Plug-in Hybrid Electric Vehicle now!

Please dial Enginer assistance hotline on 877-886-8897 if you encounter difficulty or risk during and after installation.

Enginer very much appreciates your action of saving the earth and wishes you enjoy your driving with the new PHEV.

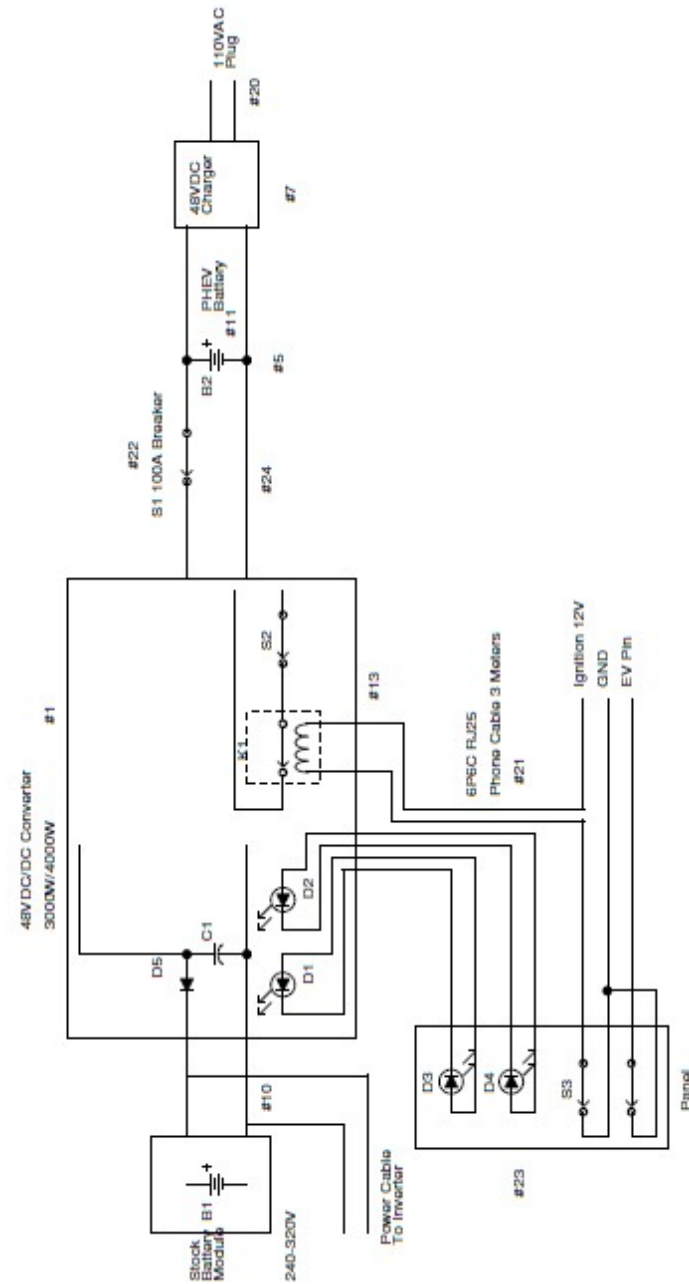

NOTE: